



STOURFLEX®

J & P Supplies Ltd

Expansion Joints & Pipeline Equipment

Installation, Operation and Maintenance Instructions for Flanged Stainless Steel Pump Connectors : Tied and Untied.

Storage.

Stainless steel flanged pump connectors should be stored in a clean dry area and be protected from damage caused by other items of plant and equipment.

Inspection.

Stainless steel flanged pump connectors should be inspected for external damage to the stainless steel convolutions prior to installation

Selection.

Check that the correct stainless steel flanged pump connector has been selected for the operating conditions that exist. If the pump connector is being used on potable or domestic hot water services ensure the unit has been supplied with stainless steel flanges.

Installation.

Stainless steel flanged pump connectors should be fitted at their correct installation length. They should not be compressed or extended. Pipework should be true and straight and adjustments made if dimensions exceed movement capabilities of the pump connectors being installed.

Correct Installation Length.

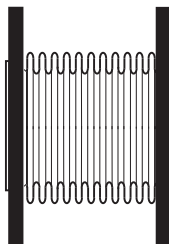

Extension.

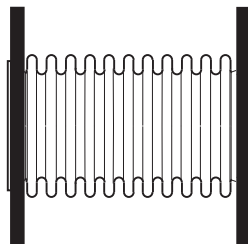

Compression.

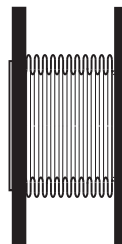

Angulation.



Correct Installation Length.



Extension.

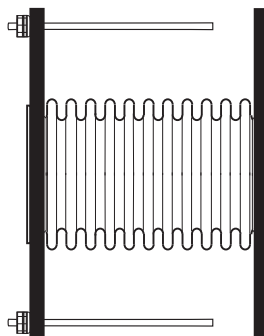

Compression.

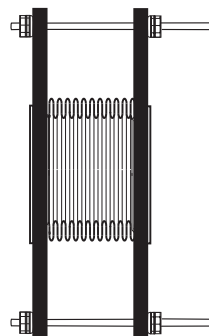

Angulation.

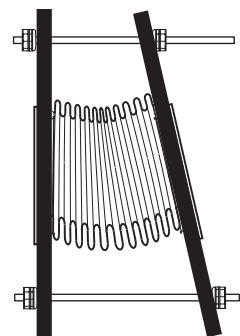



STOURFLEX®

J & P Supplies Ltd

Expansion Joints & Pipeline Equipment

Installation, Operation and Maintenance Instructions for Flanged Stainless Steel Pump Connectors : Tied and Untied.

Installation Continued. When tied stainless steel flanged pump connectors are being used they must be installed at their correct installation length. Ensure that the conical steel washers have been correctly fitted. Tie bar assemblies should be uniformly tightened and bolts rechecked after approximately seven days.

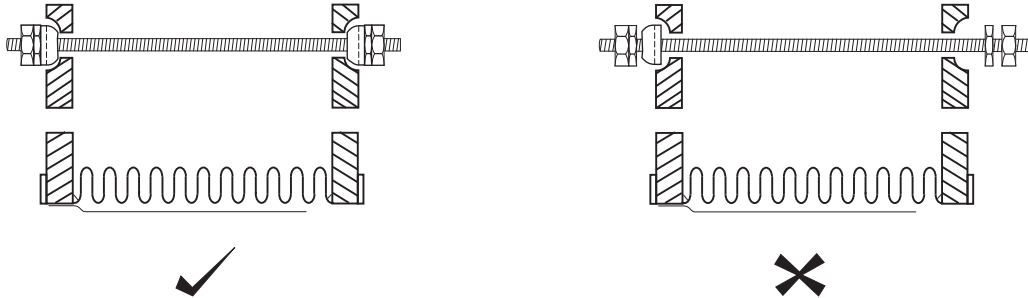

Test Pressure. If a hydraulic pressure test is to be carried out on a system containing pump connectors ensure that the anchors have been correctly fitted before the test is carried out. Also ensure that the test pressure (usually 1.5 working) does not exceed the test pressure of the pump connector being installed.

Anchoring. Stainless steel flanged pump connectors must be anchored to ensure their correct performance.

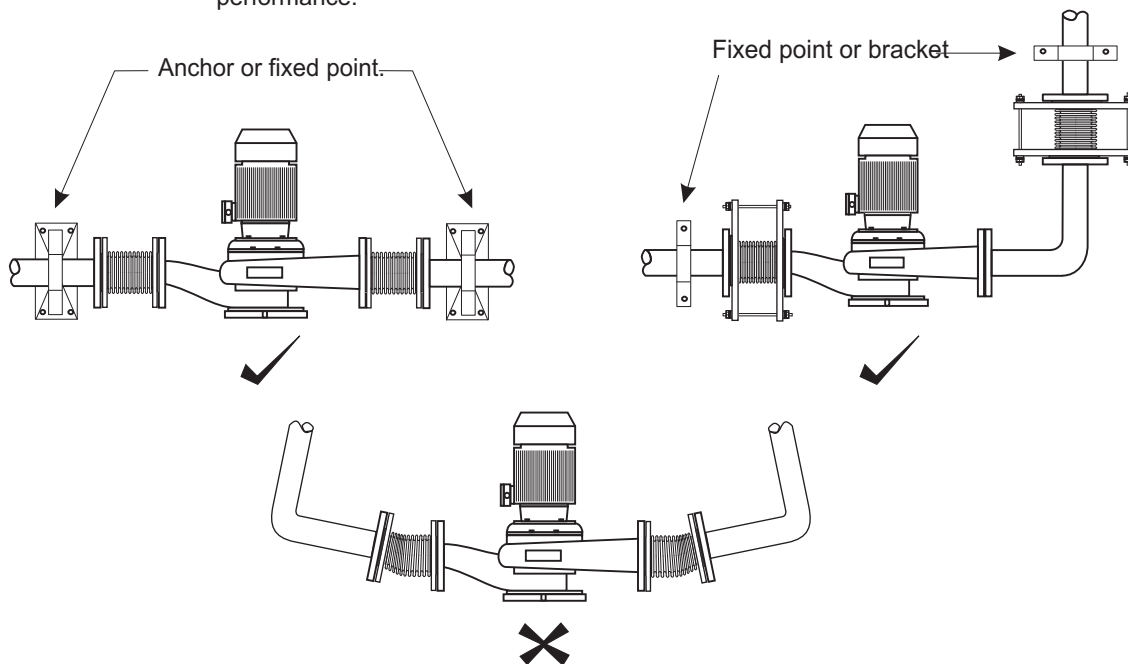

Stainless steel flanged pump connectors will exert a pressure thrust in service and must be anchored to protect adjacent pipework and equipment. Stainless steel flanged pump connectors will extend under pressure and must be anchored to prevent this happening.

Maintenance When properly installed and used at their correct operating temperature and pressure stainless steel flanged pump connectors will give many years of trouble free service. However they should be periodically inspected for signs of deterioration. End connections and flange bolts should also be checked and re-tightened if necessary. If insulation is to be used this should be removable to allow inspection to be carried out.