



# STOURFLEX®

J & P Supplies Ltd

Expansion Joints & Pipeline Equipment

## Type JP502 Air Separator Flanged.

**Specification** Micro Bubble Air Separator manufactured from corrosion resistant 316L stainless steel fitted with silumin swivel flanges drilled to BS4504 NP10.

**Application** Stourflex Nonair micro bubble air separators are designed to remove air from circulating heating and chilled water systems.

Maximum working temperature 110 °C.  
Maximum working pressure 10 Bar.  
Maximum test pressure = 1.5 x working pressure.

For efficient air removal separators should be line size.

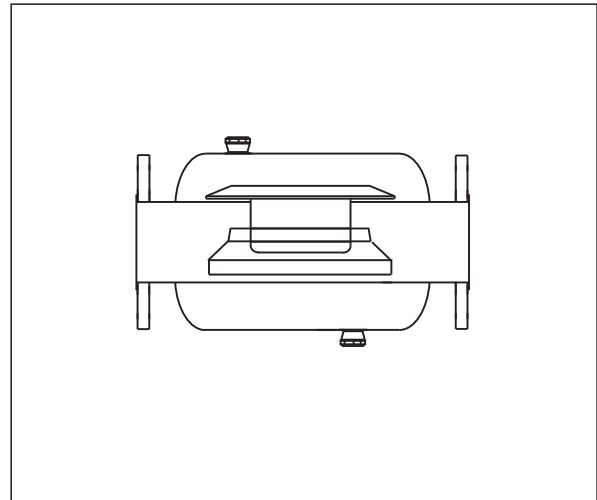

Part Number	N.B. (mm)	Installed Length (mm)	Body Diameter Excluding Airvent and Drain Valve (mm)	Dry Weight (Kg)	Volume (Litre)	Air Vent Connections Female bsp		Drain Connection Female bsp (")
						No	(")	
JP502-50	50	305	129	3	3	1	½	½
JP502-65	65	365	154	4	5	1	½	½
JP502-80	80	405	168	7	6	1	½	½
JP502-100	100	455	204	9	8	1	½	½
JP502-125	125	505	256	11	16	2	½	½
JP502-150	150	555	306	16	25	2	½	½
JP502-200	200	660	406	35	56	2	½	1
JP502-250	250	920	458	60	103	2	½	1
JP502-300	300	960	550	112	165	3	½	1
JP502-350	350	1095	610	147	225	3	½	1
JP502-400	400	1185	700	195	329	3	½	1

Stainless Steel Automatic Air Vents and Shut Off Valves are available for all Stourflex Nonair Separators.

Weld and Grooved ends, alternative flange drillings and materials available upon request.

Where dirt separation is also required please refer to the Stourflex Nonair **Type JP503** and **JP504**.

Please refer to guidance notes for the correct use and installation of Stourflex Nonair Separators.

Installed lengths may vary, if an exact installation length is required please check at time of order.

09/2010/N2