



STOURFLEX®

J & P Supplies Ltd

Expansion Joints & Pipeline Equipment

Type JP123 Angular Expansion Joint Van Stone Flanged.

Specification Single hinged angular expansion bellows consisting of stainless steel grade 321 bellows fitted with carbon steel van stone flanges and hinge assembly drilled to BS 4504 NP16.

Application Stourflex single hinged angular expansion joints are used in sets of two or three and are generally installed in changes in pipework direction. They will accommodate lateral movement in only one plane. This movement occurs due to thermal expansion or contraction or building settlement. The **Type JP123** is manufactured to have all stainless steel wetted surfaces and are suitable for use on non ferrous pipework installations including L.T.H.W., M.T.H.W., H.T.H.W., steam and other hot liquids and gases.

Maximum working temperature 300°C.
Maximum working Pressure 16 bar at 120°C.

Stourflex angular expansion joints should not be used at both their maximum working temperature and pressure respectively. Maximum test pressure = 1.5 x working pressure or 1.5 x flange rating whichever the lower.

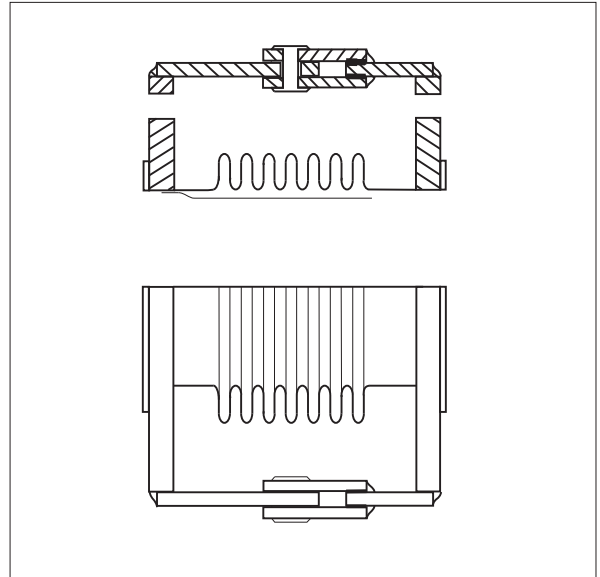

Part Number	N.B. (mm)	Angulation (Degree)	Overall Length (mm)	Angular Spring Rate (N.mm/deg)	Working Pressure @120°C (bar)	Cold Test Pressure (bar)
JP123-50-16	50	5	133	10.7	16	24
JP123-65-16	65	5	133	13.8	16	24
JP123-80-16	80	5	133	46.5	16	24
JP123-100-16	100	5	133	75.7	16	24
JP123-125-16	125	6.5	199	50.1	16	24
JP123-150-16	150	6.5	199	94.3	16	24
JP123-200-16	200	7	212	135	16	24
JP123-250-16	250	7	212	241	16	24
JP123-300-16	300	7	212	379	16	24

Stainless steel grade 321 internal flow sleeve fitted as standard.

Where service conditions above 300°C or 16 bar exist or where additional movement is required non standard variations of the **Type JP123** are available if required.

Alternative flange drillings are available.

Stourflex angular expansion joints are supplied at their maximum overall length and must not be extended. Angular expansion joints must be securely anchored and adequately guided to ensure their correct performance. Omitting anchors and guides may result in failure of the system.

All Stourflex products should be installed in accordance with our fitting instructions.