



# STOURFLEX®

J & P Supplies Ltd

Expansion Joints & Pipeline Equipment

## Type JP23VS

### Tied Stainless Steel Flanged Pump Connectors.

#### Specification

Tied stainless steel pump connector consisting of multi - ply stainless steel grade 321 bellows assembly and mating surfaces (stainless steel wetted parts) fitted with zinc plated carbon steel van stone oval flanges complete with fully threaded tie bars and rubber top hat washers. Drilled to BS4504 NP16.

#### Application

Tied Stourflex stainless steel pump connectors are designed to reduce noise and vibration from pumps and reciprocating machinery. They are suitable for use on HWS, L.T.H.W., M.T.H.W., Steam, Gasses and other non ferrous applications.

Maximum working temperature 300°C.  
 Maximum working pressure 16 bar.  
 Stourflex tied stainless steel flanged pump connectors should not be used at both their maximum working temperature and pressure respectively.  
 Maximum test pressure = 1.5 x working pressure or 1.5 x flange rating, whichever the lower.

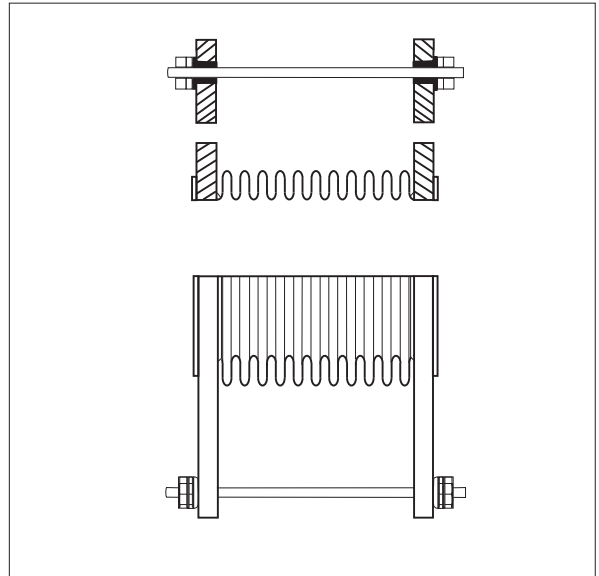

Certificate No: 0902078

| Part Number. | N.B. (mm) | Installed Length. (mm) | Axial Movement (± mm) | Lateral Movement (± mm) | Max. Working Pressure (bar) | Max. Cold Test Pressure (bar) |
|--------------|-----------|------------------------|-----------------------|-------------------------|-----------------------------|-------------------------------|
| JP23VS-32    | 32        | 130                    | 3                     | 2                       | 16                          | 24                            |
| JP23VS-40    | 40        | 130                    | 3                     | 2                       | 16                          | 24                            |
| JP23VS-50    | 50        | 130                    | 3                     | 2                       | 16                          | 24                            |
| JP23VS-65    | 65        | 130                    | 3                     | 2                       | 16                          | 24                            |
| JP23VS-80    | 80        | 130                    | 3                     | 2                       | 16                          | 24                            |
| JP23VS-100   | 100       | 130                    | 3                     | 2                       | 16                          | 24                            |
| JP23VS-125   | 125       | 130                    | 3                     | 2                       | 16                          | 24                            |
| JP23VS-150   | 150       | 130                    | 3                     | 2                       | 16                          | 24                            |
| JP23VS-200   | 200       | 200                    | 5                     | 2                       | 16                          | 24                            |
| JP23VS-250   | 250       | 200                    | 5                     | 2                       | 16                          | 24                            |
| JP23VS-300   | 300       | 200                    | 5                     | 2                       | 16                          | 24                            |

Where vacuum conditions or pressure and temperatures exist above those stated, please check with us the suitability of and effects on service life of Stourflex products.

Tie bar assemblies can be fitted with, rubber top hat, steel conical, or steel mesh washers, to suit application and temperature.

Stourflex **Type JP23VS** tied stainless steel flanged pump connectors are available with stainless steel 321 internal flow sleeve on request.

Alternative flange materials and drillings are available on request.

Please refer to guidance notes for the correct use and installation of Stourflex tied pump connectors.

Stourflex products should be installed in accordance with our fitting instructions.