



# STOURFLEX®

J & P Supplies Ltd

Expansion Joints & Pipeline Equipment

## Type JP06

### Tied Rubber Bellows. High Temperature Water.

#### Specification

Tied E.P.D.M. rubber bellows with high tensile cord reinforced body and steel reinforced collars. Fitted with zinc plated carbon steel oval flanges complete with fully threaded tie bars and rubber top hat washers. Drilled to BS 4504 NP 16.

#### Application

Stourflex tied rubber bellows are designed to accommodate misalignment and lateral movement. They are also used to reduce noise and vibration from pumps and reciprocating machinery. The high tensile cord reinforced body allows the **Type JP06** to be used on heating systems and engine cooling applications or where extended service life is required.

Maximum working temperature 105°C.  
( Intermittent peaks up to 120°C. )  
Maximum working pressure 16 Bar.  
Maximum working pressure at 105°C = 6 bar.  
Maximum working pressure at 90°C = 10 bar.  
Stourflex rubber bellows should not be used at both their maximum working temperature and pressure respectively.  
Maximum test pressure = 1.5 x working pressure or 1.5 x flange rating, whichever the lower.

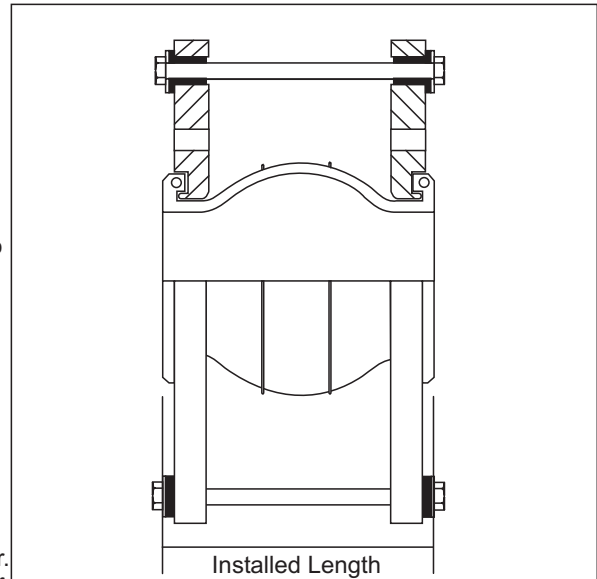

Part Number.	N.B. (mm)	Tie Bars	Installed Length. (mm)	Movement.		Pressure.	
				Lateral (mm)	Working Pressure. up to 60°C (bar)	Vacuum.	
						Without Support Ring (mm Hg)	With Support Ring (mm Hg)
JP06-32-16	32	2	130	10	16	500	750
JP06-40-16	40	2	130	10	16	450	750
JP06-50-16	50	2	130	10	16	450	750
JP06-65-16	65	2	130	10	16	350	750
JP06-80-16	80	2	130	10	16	350	750
JP06-100-16	100	2	130	10	16	300	600
JP06-125-16	125	2	130	10	16	250	600
JP06-150-16	150	2	130	10	16	250	600
JP06-200-16	200	2	130	10	16	200	500
JP06-250-16	250	2	130	10	16	100	500
JP06-300-16	300	4	130	10	16	100	500

The movements stated above have been reduced to cater for high temperature applications.

Where vacuum conditions or pressures and temperatures above those stated exist, please check with us the suitability of and effects on service life of Stourflex products. Vacuum support ring fitted on request.

Stourflex products should be installed in accordance with our fitting instructions. Stourflex rubber bellows should be periodically inspected and replaced if any deterioration is evident.

The **Type JP06** rubber bellows are produced within the E.E.C. and are stamped with date of manufacture. The **Type JP06** conforms with and is certified to **DIN 4809**.

09/2010/A6