



STOURFLEX®

J & P Supplies Ltd

Expansion Joints & Pipeline Equipment

Type JP05 Untied Rubber Bellows. High Temperature Water.

Specification Untied E.P.D.M. rubber bellows with high tensile cord reinforced body and steel reinforced collar. Fitted with zinc plated carbon steel swivel flanges drilled to BS. 4504 NP16.

Application Stourflex untied rubber bellows are designed to accommodate misalignment and both axial and lateral movement. They are also used to reduce noise and vibration from pumps and reciprocating machinery. The high tensile cord reinforced body allows the **Type JP05** to be used on heating systems and engine cooling applications or where extended service life is required.

Maximum working temperature 105°C. (Intermittent peaks up to 120°C)
 Maximum working pressure 16 Bar.
 Maximum working pressure at 105°C = 6 bar. Maximum working pressure at 90°C = 10 bar. Stourflex rubber bellows should not be used at both their maximum working temperature and pressure respectively.
 Maximum test pressure = 1.5 x working pressure or 1.5 x flange rating, whichever

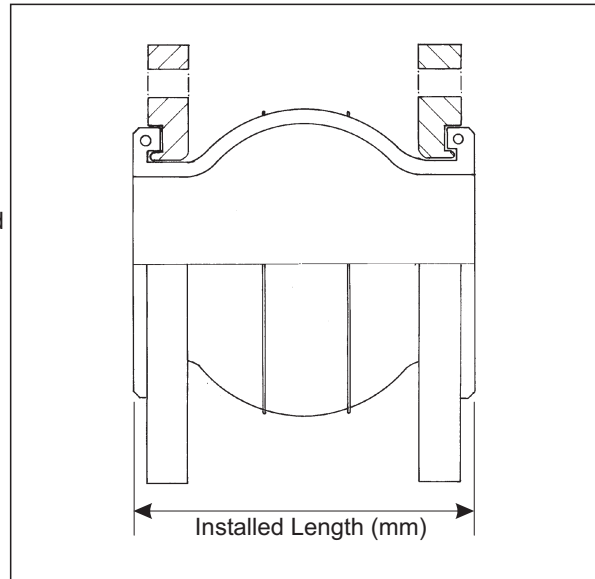

Part Number.	N.B. (mm)	Installed Length. (mm)	Movement.				Pressure.		
			Compression (mm)	Extension (mm)	Lateral (mm)	Angular	Working Pressure. up to 60°C (bar)	Vacuum.	
								Without Support Ring (mm Hg)	With Support Ring (mm Hg)
JP05-32-16	32	130	15	15	10	15°	16	500	750
JP05-40-16	40	130	15	15	10	15°	16	450	750
JP05-50-16	50	130	15	15	10	15°	16	450	750
JP05-65-16	65	130	15	15	10	15°	16	350	750
JP05-80-16	80	130	15	15	10	15°	16	350	750
JP05-100-16	100	130	15	15	10	10°	16	300	600
JP05-125-16	125	130	15	15	10	10°	16	250	600
JP05-150-16	150	130	15	15	10	10°	16	250	600
JP05-200-16	200	130	15	15	10	6°	16	200	500
JP05-250-16	250	130	15	15	10	6°	16	100	500
JP05-300-16	300	130	15	15	10	6°	16	100	500

The movements stated above have been reduced to cater for high temperature applications.

Where vacuum conditions or pressures and temperatures above those stated exist, please check with us the suitability of and effects on service life of Stourflex products. Vacuum support ring fitted on request.

Details on larger sizes and alternative flange specifications are available on request.

Stourflex products should be installed in accordance with our fitting instructions. Stourflex rubber bellows should be periodically inspected and replaced if any deterioration is evident.

The **Type JP05** rubber bellows are produced within the E.E.C. and are stamped with date of manufacture. The **Type JP05** conforms with and is certified to **DIN 4809**.